



Vista

The Vista Cubicle system offers full height cubicles with a flush façade, clean aesthetics and sleek fittings.



Vista SGL

Rebated doors, minimal floor clearance and full height panels combined.

Specification

Pilasters/Divisions/Doors:

Panel Specification:

Please note we strongly recommend this SGL Panel Option for high traffic and wet areas.

- SGL Core/Face: Solid grade laminate with colour finish to both sides giving 13mm nominal thickness
- Panel Detail: Rebated doors/ pilasters to create a flush front cubicle
- Edge: Polished and radiused
- Colour: From the Dunhams colour selector

Hardware:

All fittings manufactured from high quality brushed stainless steel

- Pedestals: Stainless steel cylindrical design
- Hinges: Sprung butt hinges for self-closing doors
- Indicator Bolt: Stainless steel indicator bolt turn with emergency release facility
- Partition Fixing: Partitions secured with stainless cleats and stainless steel bolt-thru fixings
- Headrail: Minimalist U channel headrail

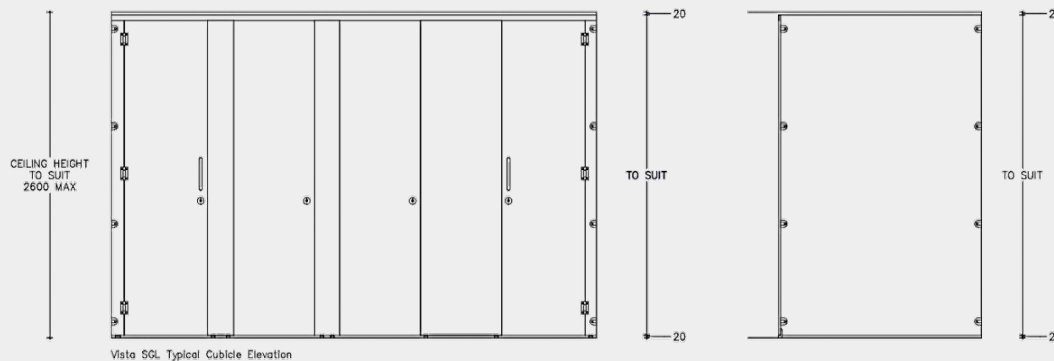
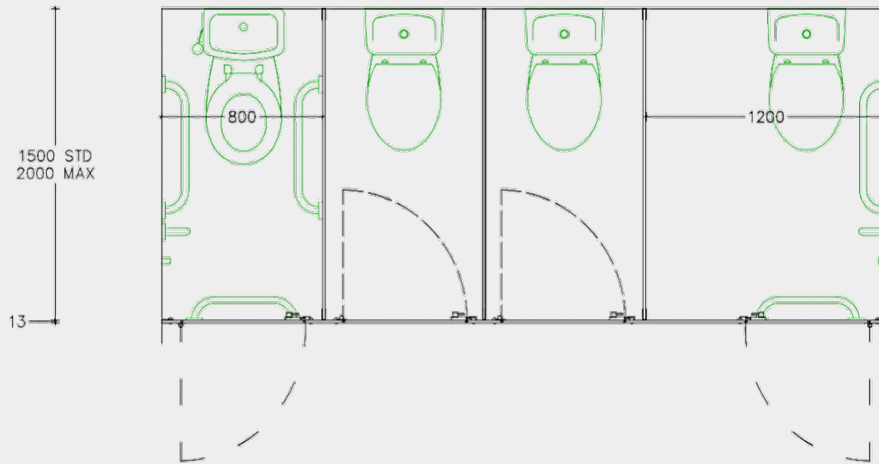

Vista SGL Typical Cubicle Elevation

Toilet Cubicles solution for:

- ▶ Shower/ Changing Rooms
- ▶ Office
- ▶ Retail
- ▶ Entertainment

Features:

- Flush front façade
- Rebated door sets for enhanced privacy
- Superior quality stainless steel hardware
- Innovative concealed pilaster fixing
- 20mm minimal floor clearance
- Suitable for shower cubicles

Complementary Options:

- Vanity Units and Duct Panel Systems are available to complement Vista Cubicles

Find out more at [dunhamswashrooms.com](https://www.dunhamswashrooms.com) or call 01603 424855

